

MOTOROLA

MODEL
 AMERICAN MOTORS 8990494
 MOTOROLA 84MA

(Continued on page 95)

CAUTION
 "A" LEAD MUST BE CONNECTED TO POSITIVE (+) SIDE OF POWER SUPPLY. RADIO WILL NOT OPERATE AND DAMAGE TO COMPONENTS WILL RESULT IF CONNECTED OTHERWISE.

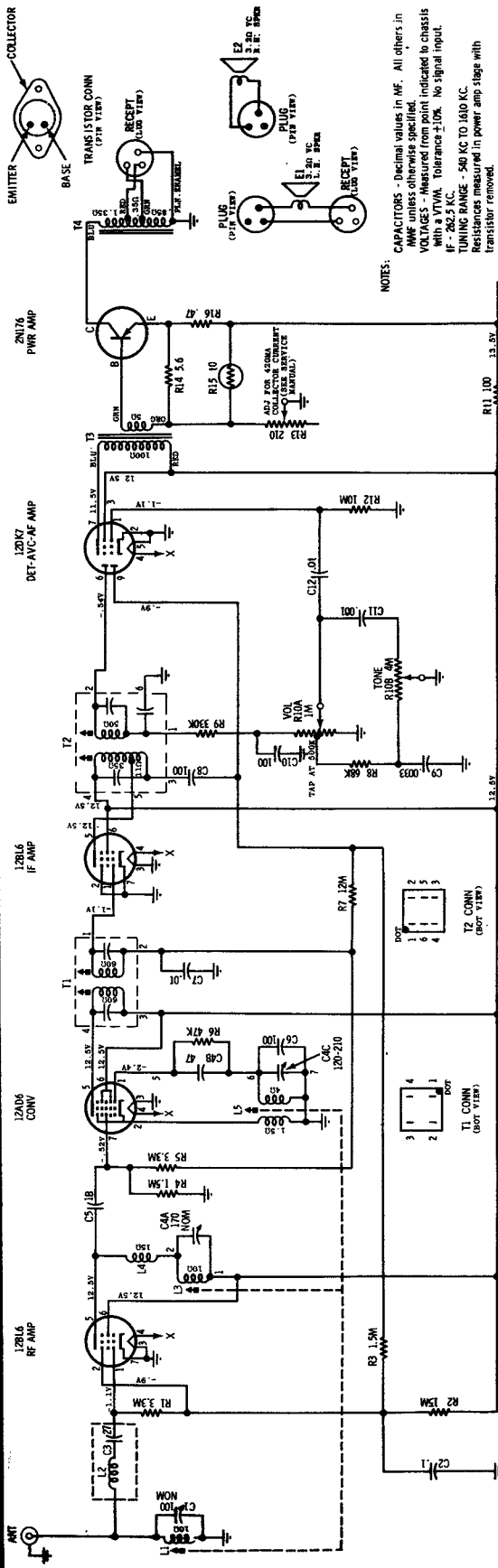
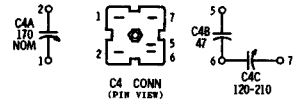

NOTES:
 CAPACITORS - Decimal values in MF. All others in μ F unless otherwise specified.
 VOLTAGES - Measured from point indicated to chassis with a VTVM. Tolerance $\pm 10\%$. No signal input.
 IF - 262.5 KC.
 RF - 160 RANGE - 540 KC TO 1600 KC.
 Resistor marked 'R' in power amp stage with transistor removed.

SERVICE NOTES

- RADIO POLARITY** - WHEN SERVICING THIS RECEIVER ON THE SERVICE BENCH, BE SURE THAT THE RECEIVER "A" LEAD IS CONNECTED TO THE POSITIVE SIDE OF THE POWER SOURCE AND THAT THE RECEIVER HOUSING IS CONNECTED TO THE NEGATIVE SIDE. IF CONNECTED OTHERWISE, THE RECEIVER WILL NOT OPERATE AND DAMAGE TO COMPONENTS MAY RESULT.
- POWER SUPPLY REQUIREMENTS** - It is preferable to use a storage battery (without a battery charger) in place of a battery eliminator when servicing this receiver, because the average eliminator has an extremely high AC ripple content which may damage the transistor and other low voltage components. The average output of the eliminator may be read as 14 volts, but the peak ripple may actually be 15 to 25 volts or higher. Only a well filtered and regulated eliminator type power supply should be used to service this receiver in place of the storage battery recommended.
- SERVICING PRECAUTION** - When servicing this receiver, probing with a screwdriver (checking for spark to ground from various points) must be avoided, because the plate power is obtained directly from the storage battery and high currents can flow through the components causing permanent damage. The transistor stage is especially susceptible to damage from this type of check. If the transistor BASE electrode is shorted to ground (either directly or through any other path) the BASE bias will be removed allowing excessive current to flow through the transistor causing permanent damage by melting the indium junctions in the transistor.
- TRANSISTOR REPLACEMENT** - When replacing a transistor, be sure that the transistor insulator is in place and that the mounting screws are securely tightened. If insulator is not in place the transistor will be shorted to chassis and set will not operate. If mounting screws are not tight, the transistor will be damaged due to a lack of proper heat dissipation. NOTE: When a transistor is replaced the current should be checked (see SERVICE NOTE 5 and 6).
- TRANSISTOR CURRENT ADJUSTMENT** - After replacing transistor and before connecting radio to power supply, set the transistor bias control (R-13) to the maximum (fully counterclockwise) position to prevent excessive current from damaging the transistor. Allow about 15 minutes warm-up time before proceeding with the following:
 - Connect a VTVM from transistor collector electrode (external shell) to chassis.
 - Adjust R-13 for .98 volts on VTVM. (This corresponds to a collector current of 420 MA).
 - Repeat Step b after a half hour.
- TRANSISTOR INSULATOR** - When replacing a transistor or transistor insulator, be sure to coat both sides of insulator with DC-4 grease (Motorola Part No. 11M490487) to insure proper heat dissipation.
- TRANSISTOR CHECK** - Substituting a known good transistor for a suspected one is the simplest and most positive method of checking transistors.

VOLUME R-18, MOST-OFTEN-NEEDED 1958 RADIO SERVICING INFORMATION

MOTOROLA Model 84MA, American Motors 8990494, Continued from page 94

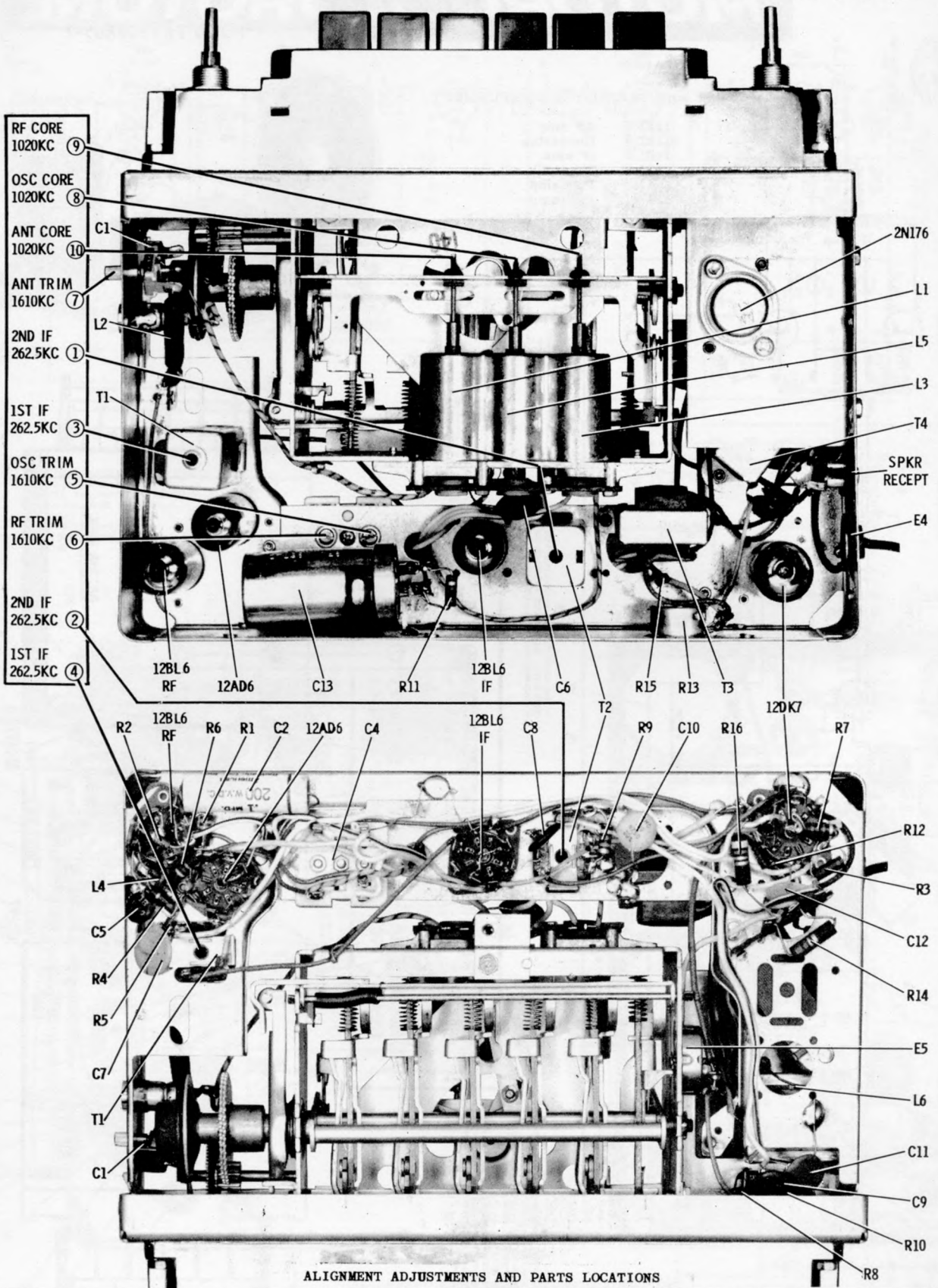

ALIGNMENT ADJUSTMENTS AND PARTS LOCATIONS